

The Solar Mass Ejection Imager

B.V. Jackson, A. Buffington, P.L. Hick
Center for Astrophysics and Space
Sciences, UCSD
La Jolla, CA 92093, USA

S.W. Kahler
Phillips Laboratory/GPSG,
Hanscom AFB, MA 01731, USA

S.L. Keil
Phillips Laboratory/GPSS,
National Solar Observatory
Sacramento Peak
Sunspot, NM 88349, USA

G.M. Simnett
School of Physics and Space Research
University of Birmingham
Edgbaston, Birmingham B15 2TT, UK

D.F. Webb
ISR, Boston College
Newton Center, MA 02159, US

KEYWORDS

Coronagraphs - Stray light - Corona - Heliosphere

ABSTRACT

We are designing a Solar Mass Ejection Imager (SMEI) capable of observing Thomson-scattered signals from transient density features in the heliosphere from a spacecraft situated near 1 AU. The imager is designed to trace these features, which include coronal mass ejections, corotating structures and shock waves, to elongations greater than 90° from the Sun. An imager at Earth could allow up to three days warning of the arrival of a mass ejection from the Sun. The instrument can be regarded as a progeny of the heliospheric imaging capability shown possible by the zodiacal light photometers of the HELIOS spacecraft. The instrument we are designing must utilize one of the most advanced baffle systems yet devised to eliminate sunlight from its wide angle field of view. In addition, the instrument must couple the wide field of view to a CCD camera so that the small percentage variations of the Thomson-scattered signals can be detected relative to a much brighter zodiacal light and stellar background.

INTRODUCTION

The Solar Mass Ejection Imager (SMEI) is designed to map large-scale variations in heliospheric electron densities as seen in Thomson-scattered light from Earth orbit. The imager will detect, measure, track and

forecast the arrival at Earth of heliospheric features, such as coronal mass ejections, shocks and co-rotating structures. In concept, SMEI will operate much like the imaging capability shown possible by the HELIOS zodiacal light photometers (Jackson and Leinert, 1985, and see references therein and in this review), but with far higher spatial resolution. A portion of an early prototype version of the instrument (baffle, optics, and some of the data analysis schemes) has been constructed for preliminary study (Jackson *et al.* 1991). In the first section of this review, we give the signal levels at 1 AU based on the HELIOS spacecraft data. The second section describes the SMEI instrument configuration for Earth orbit. A variety of background sources of light that could dilute or confuse the heliospheric signal is given in the last sections of the review, followed by a brief conclusion.

SIGNAL LEVELS AND PHOTON NUMBERS

Because the faint coronal features we wish to detect are much less bright than the Sun, the SMEI must be designed carefully to eliminate stray light. The brightnesses of coronal mass ejections (CMEs) (Figure 1) and streamers were derived from features traced outward from the Naval Research Laboratory SOLWIND coronagraph (Sheeley *et al.* 1980) and the High Altitude Observatory SMM coronagraph (MacQueen *et al.* 1980) and from features observed with the HELIOS photometers (Leinert *et al.* 1981) by Richter *et al.* (1982) and others (Jackson, 1985; Webb and Jackson, 1990; Jackson, 1991; Webb *et al.*, 1995). Shock brightnesses were estimated from the *in situ* plasma density enhancements behind shocks observed from the HELIOS spacecraft and assumed to be viewed at 60° and 90° elongations - angular distances from the Sun-spacecraft line (Jackson, 1986). The comet shock estimates are from Jackson and Benensohn (1990). Signal levels in Table 1 are given in terms of "S10 units", the equivalent flux of a single tenth magnitude star per square degree of sky.

Table 1. Signal Levels Expected at 1 AU

Feature	Elongation (degrees)	Signal Intensity (S10)	Signal Duration (days)
Bright CME	60	2	1.5
	90	1	1.5
Bright streamer	60	2	1
	90	1	1
Bright shock	90	0.5-1	≤0.5
Major unidentified	60	3	2
<i>in situ</i> fluctuation	90	2	2
Comet shock	20	3-10	--

The Thomson-scattered coronal light must be detected in the presence of background diffuse light from many sources: scattered light from bright sources such as the Sun, Moon, or Earth; the zodiacal light; and the stars, either individually as bright point sources or collectively as a contribution to the diffuse sky brightness. Figure 1 is a plot of estimates of the brightness contributions from these signals to

be observed from an Earth-orbiting SMEI at different elongations from the Sun. The Sun is the equivalent of 5×10^{14} S10 units.

The ultimate limit of diffuse-light sensitivity should be set by photon counting statistics; this limit depends upon the optics and scanning configuration, the spectral bandpass, and the total detector efficiency. The total detected photon count N can be approximated as did Jackson *et al.* (1989) by

$$\log N = 6.75 - 0.4m_v + \log A + \log \Delta t \quad (1)$$

where m_v is the equivalent stellar visual magnitude, A is the aperture area in cm^2 , and Δt is the integration time in seconds. Between the darkest sky and the ecliptic plane at solar elongations $\leq 20^\circ$ the background sky brightness varies roughly over the range 100-6000 S10 units. Considering $A = 2 \text{ cm}^2$, the size of the one by two cm rectangular aperture in the design for the proposed SMEI (JHU/APL, 1992) and $\Delta t = 4 \text{ s}$, then from equation (1) we obtain 4500 photons available per square degree of sky for a brightness of 1.0 S10 unit ($m_v = 10$). Detector bandpasses and other instrumental factors further decrease the number of photons which can be detected.

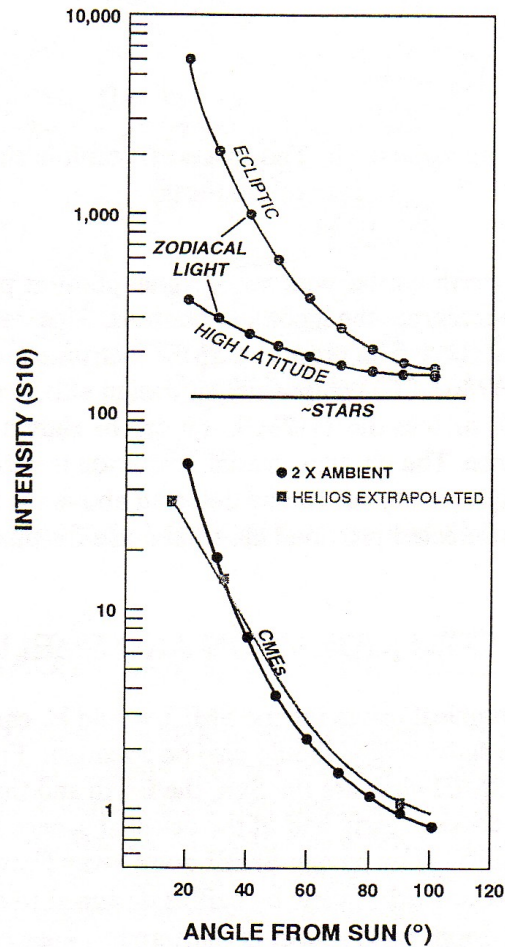

Figure 1. The brightness of various signals observed by the imager versus elongation at 1 AU.

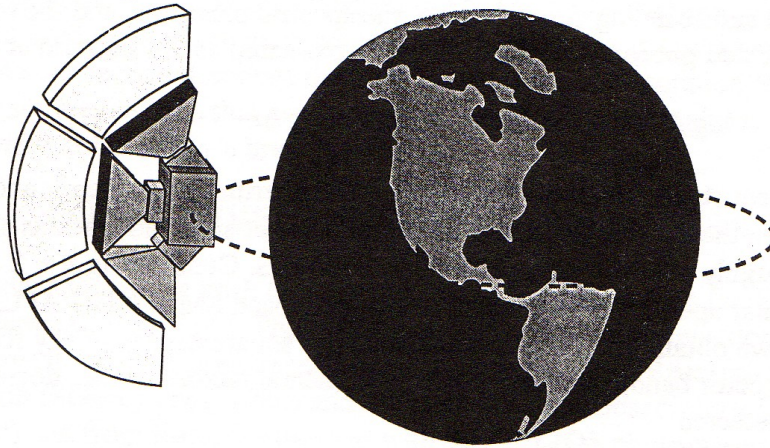

Figure 2. SMEI in a typical equatorial orbit. The spacecraft orbit is circular at 800 km above the surface of the Earth.

For a slowly rotating low-Earth orbiter with many signal photons present in each pixel, it becomes possible to use a CCD detector to integrate the incoming photons. This permits a sufficient signal to build up above a statistical noise readout level. The proposed SMEI instrument has been developed around the possibility of using a Thomson TH7863 CCD chip. Current design efforts suggest that it may be feasible to use an even larger-format CCD, such as the TH7899, if it can be shown to have a similar low pixel to pixel and subpixel variation response. The ultimate spatial resolution is determined by the smallest sky resolution element in which heliospheric signals can be detected above the far brighter zodiacal light background. The heliospheric signal is detected provided the total noise for this sky resolution element is less than the signal.

ORBITAL CONFIGURATION AND SMEI LAYOUT

One of the simplest and most economical orbits for the SMEI would be equatorial at 800 km above the Earth. A circular polar orbit at the same height should also be adequate. From such an orbit, the brightest objects to be eliminated from the SMEI view are the Sun, the Earth and the Moon. The Earth can be nearly as bright as the Sun, and it covers nearly half of the celestial sphere when viewed from low-Earth orbit. This background light is controlled by having SMEI point away from Earth. Stray light is eliminated from each of the SMEI sensor $3^\circ \times 60^\circ$ field of view by baffles designed to operate to within 18° of the solar disk and to within 1° of the Moon. Each sensor is shuttered to keep sunlight from falling directly onto the optics and CCD. Figure 2 depicts the SMEI instrumentation in an 800 km equatorial orbit. Figure 3 gives a schematic layout of the proposed SMEI instrument.

BACKGROUND SIGNALS

Light from the sky such as zodiacal light, the Milky Way and other stars is generally brighter than the variable Thomson-scattered signal we wish to detect. These contributions must be removed from the data unless they are constant from orbit to orbit. From the HELIOS orbit, the zodiacal light appears to be unchanging in time and smoothly varying spatially to near the desired detection brightness threshold for SMEI. Knowing the orientation of each data frame in the sky permits removal of this source of background light, by means of a lookup table, a mathematical algorithm, or by assuming an unchanged value from an average of previous orbits. Starlight can be dealt with in a similar fashion. However, because stars are spatially limited sources of light, the location and orientation of each sky resolution element must be known to high precision to reduce this background contribution.

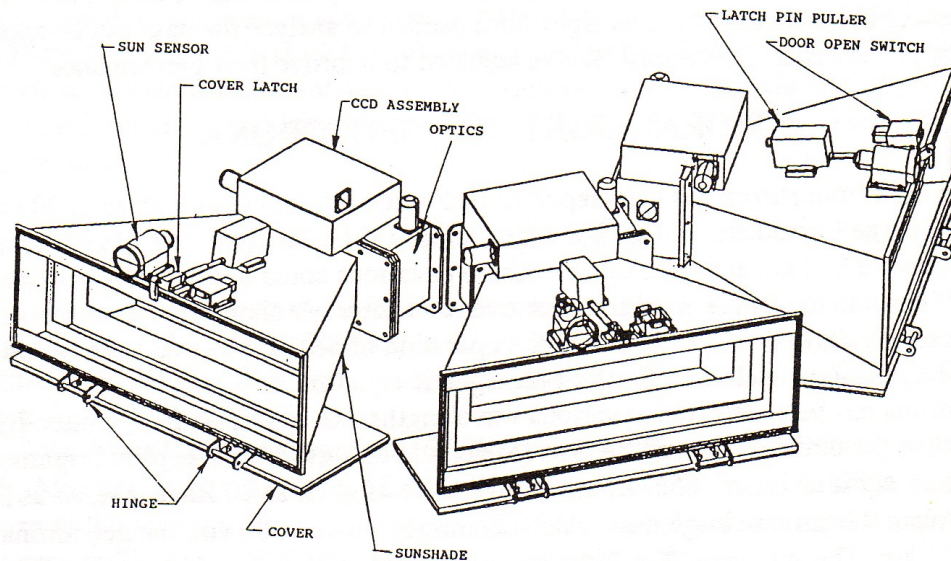

Figure 3. Layout of the proposed SMEI.

ZODIACAL LIGHT AND THE GEGENSCHIN

The zodiacal light brightness varies with ecliptic latitude (Figure 1). In principle, this light should present no problem for SMEI as long as its intensity does not saturate the imager or the statistical fluctuations of its signal do not exceed the faint Thomson scattering signal we wish to detect.

We are extremely fortunate that the HELIOS spacecraft has provided a working model for the SMEI. Hypothetically, a small percent variation in the zodiacal cloud at the spatial or temporal scales of features we wish to detect could mask the signals of interplanetary features. The HELIOS data placed an upper limit on these variations of approximately 1 S10 unit. We assume that, at the spatial and temporal scales of heliospheric brightness changes, the zodiacal cloud remains smooth and temporally non-varying even below this level. Gegenschein light, thought to be due to backscatter from the zodiacal cloud, is

present in the direction opposite the Sun at a level of about 200 S10 units. Early ground-based reports of this light being mottled at the level of 20 S10 units (Hong *et al.* 1985) are not present in the HELIOS spacecraft observations.

STARLIGHT

In general, starlight is present as discrete sources of light. However, the brightnesses of stars (Figure 1) are comparable to 120 S10 units in all directions (Allen, 1964). There is on average one eighth magnitude star in every square degree. Certain portions of the sky are brighter than others and may present problems for SMEI. These include the Milky Way and other large diffuse objects such as M31 and the large and small Magellanic Clouds. Some imager resolution elements may contain a bright or variable star that overwhelms the Thomson scattering signal at that location in the sky. These will need to be identified and removed from the record on each orbit. If the option is available to transmit all the data to the ground, as is presumed possible from most low-Earth orbiters, then on-board processing of data is not necessary and instrument electronics becomes simpler. The algorithms needed to analyze the data can be applied once the data are on the ground and, if necessary, can be adjusted to improve their performance.

AURORAL LIGHT AND GEOCORONA

On rare occasions light from aurora has been reported by Shuttle astronauts as high as 1000 km above the surface of Earth (George Carruthers, private communication, 1991). Jackson *et al.* (1992) estimate auroral brightness above 800 km and conclude that these emissions could occasionally become greater than 1 S10 unit. If aurorae this bright were to occur over time intervals short relative to successive orbital passes of the spacecraft, they could interfere with the operation of SMEI; however, this would happen only at very specific positions relative to Earth's geomagnetic equator.

The geocorona has been detected at various wavelengths, but especially in hydrogen Lyman alpha radiation as a glow in the direction toward the Sun (Meier and Mange, 1973). Typical brightnesses of the geocorona in Balmer alpha emission (6563 Å) are known to be as great as 20 Rayleighs, or as bright as ~2.0 S10 units. Unlike the aurorae brightness which diminishes above ~200 km, the geocorona is brightest at heights of >1000 km. This emission, if included in the imager bandpass, could contribute a background comparable to the signal photons observed by the SMEI at 90° elongation and greater. However, the geocorona to first order remains approximately constant relative to solar elongation and is brightest towards and to the west of the Sun (Anderson *et al.* 1987). The relative invariability of the geocorona at a given solar elongation on the time scales of mass ejections implies that this source of brightness should pose no problem for an Earth-based imager, especially if Lyman alpha is excluded from the instrument bandpass.

RAM GLOW AND OTHER SPACECRAFT-PRODUCED ILLUMINATION

Ram glow is a low-level light source which forms a comet-like halo and tail near a spacecraft in low-Earth orbit. The glow is caused by many different sources (Torr, 1988) including: a concentration of the ambient gasses which peak in the ram direction, outgassing from the spacecraft, leakage, venting and thruster firings. The amounts of this glow vary from spacecraft to spacecraft. From Space Shuttle measurements, at heights below 400 km some of the constituent molecular glows are significantly above the ~100 S10 unit zodiacal light background at 90° elongation. If the source of this light were to vary, it could cause significant problems for the imager at these heights. However, with the possible exception of sources on

the vehicle such as emissions from other experiments, these sources of light extrapolate to well below the level that could cause a detrimental effect on the imager at the 800 km orbit. Space debris are expected to be observed by the imager as frequently as about one per orbit above the tenth magnitude limit. They should be easily detected as streaks in an image.

CONCLUSION

SMEI represents a unique opportunity to causally link events on the Sun with terrestrial disturbances. The imager is a prototype of a monitoring system which will improve geomagnetic-disturbance forecasting by quantifying solar-generated disturbances and predicting their arrival at Earth. Results from the HELIOS spacecraft have demonstrated that the SMEI concept will work, and set limits on the signal levels necessary for an instrument capable of tracing solar mass ejections, corotating regions and shock waves through the heliosphere from Earth orbit. Although several designs are possible, the SMEI instrument must be deployed above the aurora and molecular glows, at an orbital height of 800 km, and will operate only when Earth is not included in its field of view. Thus, an Earth-orbiting SMEI viewing away from Earth depends on the slow orbital rotation of the spacecraft to scan the whole sky once in every 90 minute orbit. Such an instrument would have the capability of forecasting in real time the arrival at Earth of heliospheric features.

REFERENCES

- Allen, C.W., *Astrophysical Quantities*, Athlone, London, England, 1964
- Anderson, D.E., Jr., Meier, R.R., Hodges, R.R., Jr. and Tinsley, B.A.: Hydrogen Balmer alpha intensity distribution and line profiles from multiple scattering theory using realistic geocoronal models, *J. Geophys. Res.* 92, 7619, 1987
- JHU/APL: Solar Mass Ejection Imager (SMEI) Program Final Report, *SDO 9977*, 1992
- Hong, S.S., Misconi, N.Y., van Dijk, M.H.H, Weinberg, J.L and Toller G.N.: A search for small scale structures in the zodiacal cloud, In proceedings of *Properties and Interactions of Interplanetary Dust* (R.H. Giese and P. Lamy, Eds.) p. 33. Reidel, Dordrecht, 1985.
- Jackson, B.V.: Imaging of coronal mass ejections by the Helios spacecraft, *Solar Phys.* 100, 563, 1985
- Jackson, B.V.: Helios photometer measurements of in situ density enhancements, *Adv. Space Res.* 6, 307, 1986
- Jackson, B.V.: Helios spacecraft photometer observations of elongated corotating structures in the interplanetary medium, *J. Geophys. Res.* 96, 11307, 1991
- Jackson, B.V. and Leinert, C.: Helios images of solar mass ejections, *J. Geophys. Res.* 90, 10759, 1985
- Jackson, B.V. and Benensohn, R.M.: The Helios spacecraft zodiacal light photometers used for comet observations and views of the Comet West bow shock, *Earth, Moon and Planets* 48, 139, 1990
- Jackson, B.V., Hudson, H.S., Nichols, J.D., and Gold, R.E.: Design considerations for a Solar Mass Ejection Imager on a rotating spacecraft, in *Solar System Plasma Physics, Geophysical Monograph* 54, J.H. Waite, Jr, J.L. Burch and R.L. Moore, eds., 291, 1989
- Jackson, B., Gold, R. and Altrock, R.: The solar mass ejection imager, *Adv. Space Res.* 11, 377, 1991
- Jackson, B.V., Webb, D.F., Altrock, R.C. and Gold, R.: Considerations of a solar mass ejection imager in low-Earth orbit, in *Eruptive Solar Flares*, Z. Svestka, B.V. Jackson and M.E. Machado, eds., Springer-Verlag, Heidelberg, p. 322, 1992